

PART 1 — ENGLISH LANGUAGE ARTS

57 QUESTIONS

REVISING/EDITING

QUESTIONS 1-9 (PART A AND PART B)

REVISING/EDITING PART A

DIRECTIONS: Read and answer the following questions. You will be asked to recognize and correct errors so that the sentences or short paragraphs follow the conventions of standard written English. You may write in your test booklet as needed to take notes. You should reread relevant parts of the sentences or paragraphs, while being mindful of time, before marking the **best** answer for each question.

1. Which edit should be made in the sentence?

On May 8, 2018, Boston University student Zach Prescott ran a mile in 4 minutes 43.2 seconds while juggling three lacrosse balls, breaking the 32-year-old world record in jogging a sport that combines jogging and juggling.

- A. Delete the comma after **2018**.
B. Insert a comma after **student**.
C. Delete the comma after **lacrosse balls**.
D. Insert a comma after **jogging**.
2. How should the paragraph be revised?

(1) Danielle spent several hours preparing for an upcoming audition for a play at the community theater. (2) First she did vocal exercises to practice her diction and projection so that her words would carry clearly throughout the large auditorium. (3) Then she studies the text of the monologue to better understand the emotions, and motivations of the character she plans to portray. (4) Finally she recited her monologue in front of a mirror many times, making slight adjustments and improvements to her performance each time.

- E. Sentence 1: Change **spent** to **had spent**, AND insert a comma after **play**.
F. Sentence 2: Change **did** to **does**, AND insert a comma after **projection**.
G. Sentence 3: Change **studies** to **studied**, AND delete the comma after **emotions**.
H. Sentence 4: Change **recited** to **recites**, AND delete the comma after **times**.

3. How should this sentence be revised?

To promote their club, a bake sale will be sponsored by members of the debate team on Wednesday.

- A. To promote their club, on Wednesday a bake sale will be sponsored by members of the debate team.
- B. On Wednesday, to promote their club, a bake sale will be sponsored by members of the debate team.
- C. To promote their club, members of the debate team will sponsor a bake sale on Wednesday.
- D. Members of the debate team, on Wednesday to promote their club, will sponsor a bake sale.

4. Which revision corrects the error in sentence structure in the paragraph?

In September 2016 the National Museum of African American History and Culture opened as part of the Smithsonian Institution, the museum is already the Smithsonian's third most popular site. Experts say that they expect this newest Smithsonian facility to welcome nearly 4 million visitors a year. The museum features more than 30,000 objects, including Muhammad Ali's boxing gloves and a dress sewn by Rosa Parks. A commemorative copy of the Emancipation Proclamation, written in 1863 during the presidency of Abraham Lincoln, is also on display at the museum.

- E. Institution, and the
- F. year, and the
- G. objects, which include
- H. Proclamation, which was written

REVISING/EDITING PART B

DIRECTIONS: Read the text below and answer the questions following it. You will be asked to improve the writing quality of the text and to correct errors so that the text follows the conventions of standard written English. You should reread relevant parts of the text, while being mindful of time, before marking the **best** answer for each question.

The Benefits of Indoor Plants

- (1) In an age of endless media content, it is easy to see why people might prefer to stay inside. (2) According to a study sponsored by the Environmental Protection Agency, Americans spend an average of 87 percent of their time indoors. (3) Scientists say that this separation between people and nature puts people at risk for physical and psychological issues.
- (4) During the process of photosynthesis, plants convert carbon dioxide into oxygen and remove many harmful toxins from the air. (5) Spending prolonged periods of time indoors, away from plants, deprives people of these benefits. (6) Air that is not regularly detoxified can lead to a condition known as sick building syndrome. (7) This disorder first came to light in the 1970s when many office workers in the United States began to complain of unexplained flu-like symptoms. (8) Researchers determined the cause to be volatile organic compounds, or VOCs. (9) VOCs are harmful chemicals that are emitted by everyday objects such as carpet, furniture, cleaning products, and computers. (10) The NASA Clean Air Study found a simple way to remove a significant number of VOCs within a 24-hour period: add plants to indoor spaces.
- (11) Adding plants to indoor spaces has psychological benefits too. (12) Research has long linked time spent in natural environments with increased energy and feelings of contentment. (13) While being outdoors is an excellent option for improving a person's mental health, recent research has indicated that encountering natural elements while indoors can also help. (14) To experience the maximum benefit of natural elements, experts suggest placing at least one live plant per 100 square feet of home or office space.
- (15) Connecting with nature, even just by being near an indoor plant, is a significant factor in a person's well-being. (16) Sitting in front of an electronic screen all day isn't natural, and today's workers need to get up and get outdoors. (17) Richard Ryan, a psychology professor at the University of Rochester, puts it this way: "Nature is something within which we flourish, so having it be more a part of our lives is critical, especially when we live and work in built environments."

5. Which sentence should follow sentence 3 to **best** introduce the topic of the passage?
- A. Placing plants in homes and offices can provide a healthy bridge between nature and the indoors.
 - B. It is important for people to realize that they need to spend more time near plants, whether indoors or out in nature.
 - C. For their personal health and well-being, people need to spend more time outdoors or bring the outdoors in.
 - D. Individuals with little connection to nature can experience illness, depression, and higher levels of stress.
6. Which transition word or phrase should be added to the beginning of sentence 5?
- E. As a result,
 - F. Primarily,
 - G. In contrast,
 - H. Unfortunately,
7. Which sentence could **best** follow sentence 13 to support the ideas in the third paragraph (sentences 11–14)?
- A. A global study of 7,600 workers from sixteen countries revealed that employees who worked in spaces with natural elements, such as indoor plants, were more creative and productive than employees who worked in spaces without natural elements.
 - B. Specifically, a study suggests that one well-known hotel is popular among guests because its owners have made a significant investment in landscaping and indoor plants known to have a relaxing effect.
 - C. In fact, one recent study suggested that people who are routinely exposed to natural elements seem to increase their compassion for others, perhaps because that exposure generates compassion for the environment in which they live.
 - D. According to a study that was conducted in 2003, plants can reduce the amount of noise that people perceive in indoor spaces with hard surfaces, just as adding carpet can make a room seem quieter.

8. Which sentence presents ideas irrelevant to the topic of the passage and should be deleted?
- E. sentence 11
 - F. sentence 14
 - G. sentence 15
 - H. sentence 16
9. Which concluding sentence should follow sentence 17 to **best** support the information presented in the passage?
- A. Because indoor plants absorb the carbon dioxide in our air and release the oxygen we need to breathe, they are vital to our wholeness and wellness.
 - B. Experts say that adding a Boston fern, a spider plant, or an aloe vera plant is a good place to start if you want to begin to incorporate nature into your home or office.
 - C. More people should consider bringing natural elements inside to improve general wellness and reverse some of the negative effects of an indoor-centered society.
 - D. As one study has confirmed, houseplants are a wise investment because they can remove almost 90 percent of the toxins in the air within the span of 24 hours.

READING COMPREHENSION

QUESTIONS 10–57

DIRECTIONS: Read each of the following six texts and answer the related questions. You may write in your test booklet as needed to take notes. You should reread relevant parts of each text, while being mindful of time, before marking the **best** answer for each question. Base your answers only on the content within the text.

CONTINUE TO THE NEXT PAGE ►

A Memory Revolution

1 A high school senior logs on to a computer at the library to double-check the application due date listed on a college admissions website. Nearby, a librarian helps a group of biology students use a database to search for recent studies about mammals. In the past few decades, the Internet has become an integral component of daily life for many people. The seemingly limitless power of search engines made the Internet search extremely common, and today people increasingly rely on the Internet's vast accumulation of sources to access all types of information. Scientists are beginning to examine how this reliance is modifying the strategies people use to store and prioritize information in their mind.

A Dependable and Valuable Asset

2 Psychologist Benjamin Storm from the University of California, Santa Cruz, and researchers Sean Stone and Aaron Benjamin devised an experiment to study students' tendency to depend on the Internet for facts. To begin, the scientists divided sixty participants into multiple groups, including an "Internet" group and a "memory" group, and placed them in front of computers. The Internet group was required to use the search engine Google to answer eight challenging trivia questions. In contrast, participants in the memory group were permitted to use only their personal knowledge to answer the questions. In the second round, the researchers administered notably easier questions. This time, they allowed each group the option of using Google as they answered. Their results showed that 83 percent of the Internet group continued to consult Google in the second round, while only 63 percent of the memory group chose to do so.

3 People's growing inclination to rely on the Internet in order to retrieve information, particularly facts and figures, is called cognitive offloading. Canadian researcher Evan F. Risko and British researcher Sam Gilbert, who have written extensively about the topic, say a similar process has been taking place for centuries. In the past, people used resources like encyclopedias to assist their memories; however, today the Internet, serving as a vast extended memory, allows people to digitally access and retrieve much larger volumes of information. Consequently, people's minds are free for other cognitive feats, such as connecting data, learning new information, or solving problems.

Filing Information Away

4 The use of the Internet also appears to be modifying the strategies people use to store information in their mind. Researchers Betsy Sparrow from Columbia University, Jenny Liu from the University of Wisconsin-Madison, and Daniel Wegner from Harvard University conducted several studies to discover how people efficiently manage their information intake.

5 To begin, the researchers examined how people evaluate which information deserves their effort to remember. For this experiment, participants read forty trivia facts, such as "An ostrich's eye is bigger than its brain," and typed the statements into a computer file. Half the participants had been previously told the file would be saved, while half believed it would be erased. Next, the participants wrote down every fact they could recall. Those who believed the information would be erased and no longer available could recall 40 percent more facts than those who thought the information would be saved.

6 In another experiment, the same researchers tested the ability of study participants to remember where to access information. For this trial, participants read and typed trivia statements, which they saved in folders with generic names such as "Facts" and "Items." After spending ten

minutes writing down all the facts they could recall from memory, participants were asked which folder contained a particular fact based on a keyword. For example, “Which folder has the fact about ostriches?” Overall, participants recalled the information’s location more often than the content itself, correctly identifying 49 percent of the folders for specific facts while remembering only 23 percent of the actual trivia. The researchers concluded that our memory is adapting to the Internet age by prioritizing where to locate information even when the specific details are forgotten. According to Sparrow, the Internet has become an important form of transactive memory, an external source of the recollections and associative networks that constitute memory.

- 7 As the Internet’s resources continue to expand our “external” memory, some question whether the process may cause people to depend too heavily on technology. However, Steven Pinker, a professor of psychology at Harvard University, says, “Knowledge is increasing exponentially; human brainpower and waking hours are not. Fortunately, the Internet and information technologies are helping us manage, search and retrieve our collective intellectual output at different scales, from Twitter and previews to e-books and online encyclopedias. Far from making us stupid, these technologies are the only things that will keep us smart.”

HOW MEMORY WORKS

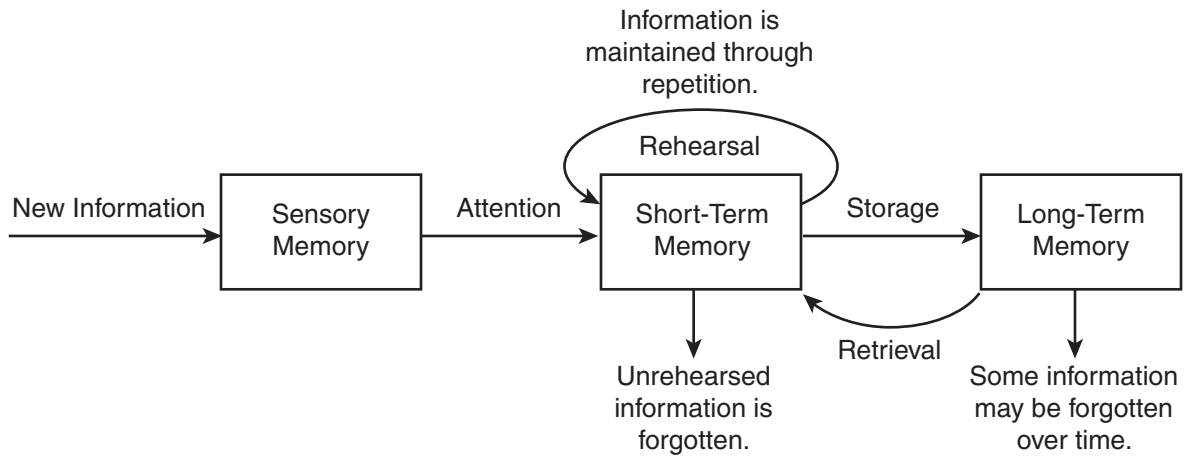

10. The details in paragraph 3 about cognitive offloading convey a central idea of the passage by
- E. suggesting that reliance on the Internet for information is inevitable.
 - F. demonstrating how the methods used to store and find information have changed over time.
 - G. explaining how encyclopedias and the Internet are similar sources of information.
 - H. implying that more information can be understood now than ever before.

11. How do the details about the experiment described in paragraph 5 convey a central idea of the passage?
- A. They suggest that the act of repeating information by typing it on a keyboard may improve a person’s memory.
 - B. They explain that a person will forget information faster if the information is considered unimportant.
 - C. They indicate that a person may start to forget details when the amount of information becomes overwhelming.
 - D. They suggest that memory is affected by whether a person expects to have access to the information in the future.
12. Read this sentence from paragraph 7.

As the Internet’s resources continue to expand our “external” memory, some question whether the process may cause people to depend too heavily on technology.

How does the sentence contribute to the structure and development of ideas in the passage?

- E. It presents a claim about the risks of relying on the Internet that prompted the research described in paragraphs 2 and 6.
- F. It contrasts a disadvantage of relying on the Internet with the benefits of Internet use that are described in paragraphs 2 and 6.
- G. It signals a shift from a neutral viewpoint in paragraphs 2 and 6 to a presentation of an argument and a counterargument.
- H. It introduces a counterargument and marks a transition from an optimistic tone in paragraphs 2 and 6 to a cautious tone as the counterargument is developed.

13. The study described in paragraph 6 influenced researchers' ideas about memory in the digital age by
- A. highlighting instances when organizing detailed information made it easier to remember.
 - B. confirming that keywords can be remembered more easily than large amounts of information.
 - C. identifying a shift in focus from remembering specific information to knowing where to find it.
 - D. emphasizing that remembering a basic idea is more important than storing detailed information.
14. Which evidence from the passage is **most** relevant to the claim in paragraph 7 that " 'far from making us stupid, these technologies are the only things that will keep us smart' " ?
- E. the revelation that most people opted to use the Internet to answer relatively easy trivia questions rather than relying on their own brainpower (paragraph 2)
 - F. the assertion that the storage of information on the Internet frees people to focus on higher-order tasks such as problem solving (paragraph 3)
 - G. the connection between how people organize information in their mind and their ability to recall that information (paragraph 5)
 - H. the description of transactive memory as an expansive external source that people can use to store information (paragraph 6)

- 15.** Which sentence from the passage suggests that using Internet search engines may lead people to rely less on their own ability to recall information?
- A.** "In the past few decades, the Internet has become an integral component of daily life for many people." (paragraph 1)
 - B.** "The Internet group was required to use the search engine Google to answer eight challenging trivia questions." (paragraph 2)
 - C.** "Their results showed that 83 percent of the Internet group continued to consult Google in the second round, while only 63 percent of the memory group chose to do so." (paragraph 2)
 - D.** "For this experiment, participants read forty trivia facts, such as 'An ostrich's eye is bigger than its brain,' and typed the statements into a computer file." (paragraph 5)
- 16.** The effect of the Internet on a person's memory is illustrated in the passage through the presentation of studies that
- E.** examine how the use of search engines changes the way people evaluate and store information for future access.
 - F.** highlight the difference between the capacity of the Internet and the ability of the human brain to locate information.
 - G.** compare the type of information that can be obtained from the Internet with the type of information that is stored in the human brain.
 - H.** emphasize the ease of obtaining information through search engines rather than remembering it without assistance.
- 17.** How does the diagram provide additional support for the topic presented in the passage?
- A.** It reveals why human brains must adapt to obtaining information from the Internet as opposed to other sources.
 - B.** It indicates how people can use the Internet to help improve their long-term recollection of information.
 - C.** It shows how study participants' brains distinguished between important and unimportant details.
 - D.** It depicts the idea that repetition and rehearsal are necessary to recall information when tools such as search engines are unavailable.

CONTINUE TO THE NEXT PAGE ►

Letter from Brooklyn

by Jacob Scheier

I can already see how this will end.
How I will grow tired of the bridge's
steep incline, and the absent-minded tourists
wandering into the bicycle path.
5 The weather will turn cold.
But that all happens later.
For now it is the early edge of fall,
leaves green still while the air narrows,
is slightly crisp, almost grazing
10 the hair of my arm like a passing stranger,
as though the air has been forced into intimacy
by the brevity¹ of daylight.
But when it starts darkening at 4,
this closeness, I know, will be a felt distance,
15 like someone drawing your attention
to their lack of intimacy.
These days I am still walking at a cathedral² pace
beneath the branches bending across avenues,
brownstones like rows of lived-in chapels,³
20 like a pop-up picture book I could have had as a child,
but didn't. How Brooklyn makes me nostalgic⁴
for the moment I am walking inside of.
These late afternoons filled
with a loneliness that makes me feel
25 distinctly myself, and an awareness
of how rare that is.

"Letter from Brooklyn" from LETTER FROM BROOKLYN: POEMS by Jacob Scheier, published by ECW Press.
Copyright © 2013 by Jacob Scheier. All rights reserved.

¹**brevity:** briefness

²**cathedral:** meditative

³**chapels:** private places of prayer or worship

⁴**nostalgic:** yearning for the past

18. How does the structure of the poem affect the poem’s meaning?
- E. The lack of a rhyming pattern suggests that the beauty of each passing day is unique.
 - F. The lengths of the sentences represent the complexity of the thoughts being represented.
 - G. The use of complete sentences implies the speaker’s appreciation for the clear beginning and ending of each season.
 - H. The single long stanza reflects the continuous flow of the speaker’s thoughts.
19. Which lines support the idea that a change in the weather will lessen the speaker’s appreciation for the city?
- A. “as though the air has been forced into intimacy / by the brevity of daylight.” (lines 11–12)
 - B. “But when it starts darkening at 4, / this closeness, I know, will be a felt distance,” (lines 13–14)
 - C. “like someone drawing your attention / to their lack of intimacy.” (lines 15–16)
 - D. “These days I am still walking . . . / beneath the branches bending across avenues,” (lines 17–18)
20. Read lines 5–6 from the poem.

**The weather will turn cold.
But that all happens later.**

How do the lines develop a central theme of the poem?

- E. They highlight a contrast between the different seasons.
- F. They show the sequence of the changes that are expected to occur.
- G. They warn about a problem that requires thoughtful preparation.
- H. They emphasize the importance of valuing the present.

21. Read lines 7–9 from the poem.

**For now it is the early edge of fall,
leaves green still while the air narrows,
is slightly crisp,**

The word choice in the lines helps convey the speaker’s belief that

- A. the beauty of the current season should still be appreciated.
- B. the changes in the weather signify the end of the most pleasant season.
- C. the transition from one season to another happens swiftly and without warning.
- D. the change in the weather is so subtle that people rarely observe or feel it.

22. The details in lines 9–12 convey a central idea of the poem by

- E. showing that the cool weather makes the speaker reflect more deeply on life.
- F. suggesting that the speaker feels uncomfortable with what the coming weather signifies.
- G. implying that the sensations the speaker experiences during the fall season are fleeting.
- H. suggesting that the thought of fall approaching increases the loneliness the speaker feels.

23. Which idea does the comparison of the brownstone houses to “a pop-up picture book I could have had as a child, / but didn’t” in lines 20–21 convey?

- A. It reveals that some people are still influenced by powerful images from childhood.
- B. It indicates that the neighborhood the speaker is walking through is charming and appealing.
- C. It suggests that the speaker has wanted to live in the neighborhood since childhood.
- D. It suggests that people often experience lingering regret from their past.

24. Read these lines from the poem.

I can already see how this will end. (line 1)

**How Brooklyn makes me nostalgic
for the moment I am walking inside of.** (lines 21–22)

The lines develop a central idea of the poem by

- E. suggesting the speaker’s desire to find a way to break free from the repetitive pattern of daily life.
- F. revealing the speaker’s feelings of disappointment over the predictable change in season.
- G. emphasizing the speaker’s awareness of the future significance of the present moment in the setting.
- H. showing the speaker’s anticipation of specific emotions caused by an intimate knowledge of the setting.

25. The speaker’s thoughts throughout the poem develop a theme by showing that

- A. although people may hold expectations for the future, some people long for present experiences while they are still happening.
- B. though people come from different places, most people feel drawn to the special charm a city holds.
- C. although people can make decisions about their life, there will always be some things beyond their control.
- D. though general expectations exist, people have no way of knowing what a given day will actually bring.

26. The poet develops the speaker’s point of view by

- E. providing details about the speaker’s longing to be in a different place.
- F. showing the speaker’s sense of unease about the passing seasons.
- G. including details about the speaker’s hope that life will remain unchanged.
- H. showing the speaker’s desire to treasure and appreciate the changes taking place.

This narrative is about the Nez Perce, an American Indian tribe, in what is now northern Idaho. The tribe is preparing for a gathering before the coming winter.

Excerpt from *Do Them No Harm!*

by Zoa L. Swayne

- 1 In the moon of Ta-Yum, the hottest days of summer, when salmon spawn in the little streams and huckleberries ripen in the high mountains, people from many villages of the Chopunnish Nation gathered in the Oyaip Prairie for the work and festivities of their annual camas¹ harvest.
- 2 From far and near The People came. . . .
- 3 Should a stranger enter their homeland and ask, “Where are you from?” the reply was always, “We are Nee-mee-poo, The People who live here in this place.”
- 4 It was a time of Lawtiwa-mah-ton—a time of being friends together—when The People came for this last chance to enjoy being together before the Cold Moons kept them close to their fires. The visiting and trading, the foot racing and horse racing, and the gambling and stick games would be remembered and talked about long after they had forgotten the drudgery of digging and roasting camas, picking berries, or drying meat and fish. Lawtiwa-mah-ton! It was good to be friends together.
- 5 As was their custom since wahk-kee-ma, a time far back beyond the memory of man, they set up their camps in the same locations their parents and grandparents had occupied before them. Red Bear’s people, from Kamiah, made their camp near the trail that came out of the mountains. Their neighbors in Kamiah Valley, The People from Tee-e-lap-a-lo, had their camp close by. Across the wide meadow, by the great roasting pits, the camps of the Te-wap-poo and Ask-kah-poo were located. The tepees and ish-nash, brush shelters, of other groups nestled in their accustomed areas in and among the pines in such numbers that they encircled the entire meadow land.
- 6 Red Bear’s people had traveled all summer with neighboring bands, gathering and preparing roots, picking and drying berries, drying and smoking meat and fish for their winter food supply. Now they were at the Oyaip camp. The women worked hard to dig and cure as many bags of roots as they could during the warm, sunny days, for the sharp night air brought warnings that WARM was going and COLD was coming.
- 7 Everyone helped in some way. Most of the men fished or hunted for meat. While many of the women dug and roasted camas, other women and older children picked and dried berries.
- 8 And the younger children played. They played at hunting. They played with the babies. They played with their horses and puppies. They learned how to live through their play.
- 9 This sun, happiness, peace, and quiet blessed the Red Bear camp. All were busy with their daily tasks, until sudden cries came from the children playing by the trail.

¹**camas:** a wild, edible plant

- 10 "People coming! People coming! People coming on the trail from the high mountains!" they called as they ran to their elders, who looked sharply at the figures of approaching horsemen.
- 11 Were they friends or enemies? Did they bring good news or bad?
- 12 "Who can it be? What brings them here?" were the questions in every mind.
- 13 "Could they be the four hunters who had gone to Buffalo Country two summers past? Would they have news of the families who had gone long ago to Buffalo Country and never returned?"
- 14 It was customary for a hunting party to be gone for more than one season.
- 15 "Looks like hunters," the older men agreed. "Looks like they had good hunting. Maybe our four hunters. [They have] been gone many moons."
- 16 "Looks like five people—not four," others observed.
- 17 Excitement grew as the riders came close enough to be recognized.
- 18 "A-a-a-a, they are our four hunters! But who is the fifth person?" they asked.
- 19 "Looks like a woman. Who is she?"
- 20 The hunters rode up to the welcoming crowd, proud to show off the loads of meat, hides, and other trophies of their hunt. They paraded around the encampment for all to see how strong their Hunting Power had been—what great hunters they, themselves, were.
- 21 Red Bear's people rejoiced at their hunters' success. Good hunters brought good to everybody. The meat meant plenty of food and the hides meant soft-tanned robes to give comfort through the Cold Moons. But it was the sight of the frail figure of the woman that aroused their curiosity. Who was she? Where had she come from? . . .
- 22 "Belongs to Red Bear people. Gone then come back," the hunters said, as they dismounted and unloaded their packs. . . .
- 23 Now they could see! She was the daughter of the family gone so long ago! The girl-child who had left came back now—a grown woman.
- 24 "Wat-ku-ese!" the women cried. "Gone-from-Home-then-Come-Back. Wat-ku-ese!" And Wat-ku-ese was her name from that time on.
- 25 Gentle arms lifted Wat-ku-ese from her horse. The women brought her food and made a place for her to rest. For many suns they cared for her until she became stronger.
- 26 One evening Wat-ku-ese told her story for all to hear.

From DO THEM NO HARM!: Lewis and Clark Among the Nez Perce by Zoa L. Swayne. Published by Caxton Press. Copyright © 1990 by Zoa L. Swayne Orofino, Idaho and Legacy House, Inc. Orofino, Idaho. All rights reserved.

27. Paragraph 1 contributes to the setting of the excerpt by establishing that
- A. the story’s location is a plentiful place that allows The People to enjoy a comfortable gathering.
 - B. the events in the story occurred in the past and are being remembered by The People.
 - C. the camp in the story is changing and that the changes are causing problems for The People.
 - D. the story’s plot begins as The People are observing their land and what it offers them.
28. In paragraphs 4 and 6, the beginning of the change in seasons affects the characters **mainly** by
- E. causing them to collect their bounty and feel eager to celebrate before it becomes cold.
 - F. making them want to rest and relax before the challenging work of the harvest begins.
 - G. forcing them to give up leisure time to prepare their camp for the coming winter.
 - H. allowing them to trade the goods they have prepared during the warm months.
29. How do paragraphs 7 and 9 convey a central idea of the excerpt?
- A. by explaining that The People often explore different areas, which shows the value of trying new things
 - B. by revealing that The People must complete many tasks, which shows the necessity of being organized
 - C. by suggesting that The People are influenced by the weather, which shows their close relationship with nature
 - D. by demonstrating that The People work together, which shows the importance of contributing to the community
30. In paragraph 8, the author repeats the word “played” **most likely** to
- E. emphasize how much the adults enjoy observing the children.
 - F. show how everyone finds a way to enjoy being at the gathering.
 - G. indicate the variety of activities available at the gathering.
 - H. characterize the manner in which the children master the work of adults.

- 31.** How do paragraphs 11–13 affect the plot of the excerpt?
- A.** They establish a feeling of mystery by presenting different points of view about the arriving people.
 - B.** They contribute to the rising action by developing the idea that the arriving people could present a problem.
 - C.** They lead to a turning point by describing the moment that the crowd realizes why the strangers have come.
 - D.** They explain the cause of the main conflict by providing background information about the strangers.
- 32.** In paragraph 20, the phrases “trophies of their hunt” and “paraded around” affect the paragraph by
- E.** suggesting that the hunters are rewarded for their leadership.
 - F.** emphasizing that The People are dependent on the hunters for food.
 - G.** revealing that the hunters are pleased with their success.
 - H.** indicating that The People have gathered specifically to welcome the hunters.
- 33.** Which quotation from the excerpt **best** supports the idea that The People feel a connection to members of their group in spite of distance?
- A.** “As was their custom since wahk-kee-ma, a time far back beyond the memory of man, they set up their camps in the same locations their parents and grandparents had occupied before them.” (paragraph 5)
 - B.** “ ‘Would they have news of the families who had gone long ago to Buffalo Country and never returned?’ ” (paragraph 13)
 - C.** “ ‘Looks like hunters,’ the older men agreed. ‘Looks like they had good hunting.’ ” (paragraph 15)
 - D.** “But it was the sight of the frail figure of the woman that aroused their curiosity.” (paragraph 21)

34. Read these sentences from paragraph 22.

“Belongs to Red Bear people. Gone then come back.”

How does this statement affect the villagers in the excerpt?

- E. It increases their concern about why the woman is in their camp.
- F. It makes them hopeful that more lost members will return before the winter.
- G. It causes shock, leading them to grieve for the loss of the woman and her family.
- H. It inspires amazement, making them want to reconnect with their returned family member.

35. The details in paragraph 5 about the locations of the camps and the details in paragraphs 23–24 about the reaction to the woman convey a theme of the excerpt by

- A. revealing the difficulties posed by moving often each year.
- B. showing the connectedness among The People through the years.
- C. indicating the value to The People of retelling stories about the past.
- D. demonstrating the importance of choosing appropriate names.

CONTINUE TO THE NEXT PAGE ►

Using Fire to Keep a Prairie Healthy

- 1 Inside the 40,000-acre Joseph H. Williams Tallgrass Prairie Preserve in northern Oklahoma, herds of bison roam on the scenic land that is home to hundreds of different species of plants and animals. While one of the greatest threats to the prairie is wildfire, the use of controlled fires is actually an effective way to protect this idyllic landscape.
- 2 Fires that are started by lightning or other natural circumstances are inevitable, and the results can be disastrous. However, hundreds of years ago the American Indian people who inhabited the Great Plains area between Minnesota and Texas realized that these fires could also be helpful. The bison in the area seemed to prefer grazing on tender new grass on the recently burned land rather than on grass in the unburned areas. The American Indian people began to deliberately burn areas of land for bison to graze on, which enticed the herds away from the people's crops.
- 3 Today conservationists at the Tallgrass Prairie Preserve and farmers in the Great Plains continue to use controlled burns for land management. Intentionally burning a portion of land can dramatically improve the quality of the vegetation that regrows there. The fires burn away weedy undergrowth and help limit the overcrowding of shrubs and trees in the burn area, creating less competition for water and nutrients. Additionally, the process of burning excess plant matter adds nitrogen, an essential element for plant growth, to the soil.
- 4 One common target of controlled burns at the preserve and the surrounding area is the invasive red cedar tree. A single red cedar tree can consume up to 40 gallons of water per day, taking this vital resource away from other plant life. These tall trees also cast shade that prevents sunlight from reaching the plants beneath them. The fast-growing red cedar trees tend to crowd out prairie grasses, the primary food source for wild and domestic animals that make the prairie their home. An imbalance in one component of the prairie's ecosystem affects the entire web of life. Controlled burns help maintain this ecosystem's delicate balance.
- 5 Of course, these controlled fires are intended to burn only a portion of an area. A total burn, which is a risk with an uncontrolled wildfire, would destroy all wildlife as well as the crops farmers plant for income. The key to using controlled fires is knowing which areas of land to burn and when. Conservation experts at the preserve employ the "patch-burn" approach, meaning they rotate which portion of land is burned each year. They study the land to find out which areas would most benefit from being burned, and then they arrange about a dozen burns over one-third of the land. This patch burning contains the fire within a specific area and allows animals in the burn area to safely relocate. The following year, conservationists will burn a different section of the preserve, while the land burned the previous year regrows healthier than before.
- 6 Researchers have tracked and studied the variety of plant species and animals that live on the preserve, and their studies show that the patch-burn approach has restored biodiversity to the area by promoting the growth of species that were at risk of being crowded out. The patch-burn system is so successful that the conservationists at the preserve provide training to prairie farmers about conducting controlled burns on their own land. Burning land to make it healthy may seem counterintuitive, but strategic controlled fires have helped the prairie sustain life for hundreds of years and, with careful management, will continue to do so.

OVERVIEW OF THE PATCH-BURN METHOD

By using a patch-burn method, conservationists and farmers can reduce the risk of unintentional fires and control where grazing animals, such as bison, roam.

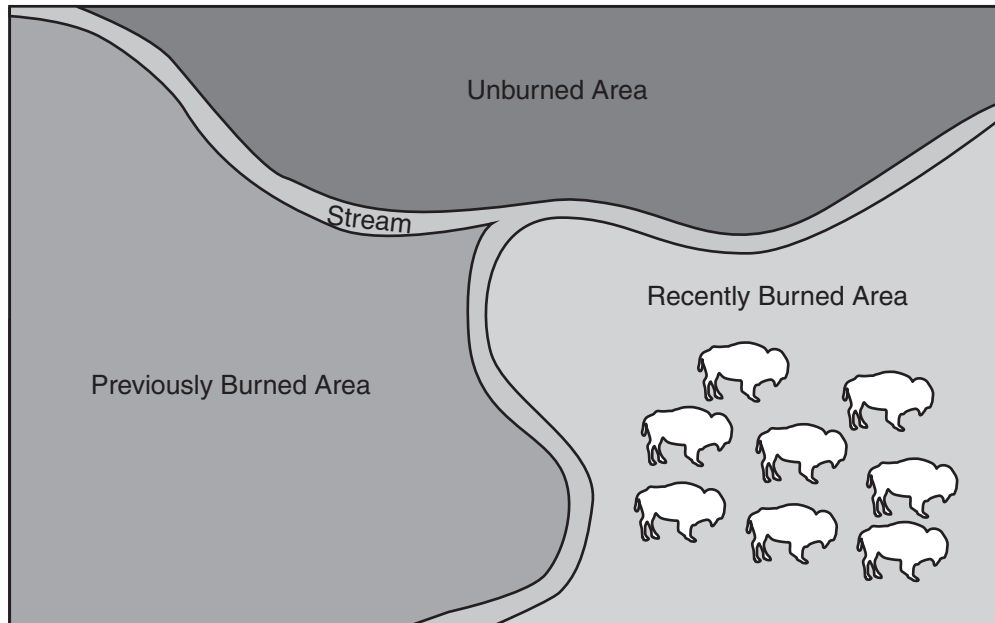

The unburned area is overrun with weeds and has the greatest risk of catching fire.

The previously burned area is cleared of weeds, and young trees and crops grow freely and thrive.

The recently burned area has been cleared of all plants. Bison prefer to eat the fresh grass that will begin to grow in the recently burned area, and they will generally remain in that area until newer, fresher grass is available elsewhere.

- 36.** According to the passage, how did fires started by natural causes prompt American Indians to begin practicing controlled burns?
- E.** by drawing animals in to the area to feed on the new growth sprouting from the burned land
 - F.** by destroying tall trees and reducing the shade that had hindered the growth of planted crops
 - G.** by burning off excess vegetation and increasing the availability of nutrients for the remaining plants
 - H.** by causing changes to the bison's migration habits as bison herds fled from the wildfires on the prairie

37. Targeting red cedar trees in controlled burns affects the animals that live on the prairie mostly by
- A. ensuring that the animals' main food source has the conditions needed for it to thrive.
 - B. endangering the animals that live near the trees scheduled for removal.
 - C. making sure that the water supply for the animals is sufficient.
 - D. reducing the animals' natural source of shade and protection from the elements.

38. Read this sentence from paragraph 6.

The patch-burn system is so successful that the conservationists at the preserve provide training to prairie farmers about conducting controlled burns on their own land.

The author includes this sentence to show that

- E. the conservationists are better qualified to lead preservation efforts than farmers are.
 - F. the conservationists are eager to involve others in the preservation of the prairie.
 - G. the conservationists' efforts will restore the original beauty and biodiversity of the region.
 - H. the conservationists' training program should serve as a model for other conservation organizations.
39. Which details from the passage **best** convey the central idea that using the patch-burn method is an effective way to protect and manage prairie land?
- A. the explanation that conservationists use the alternating burn pattern of the patch-burn method in order to allow the animals in the area to avoid the fire
 - B. the information that conservationists evaluate which land would most benefit from a controlled burn before applying the patch-burn method
 - C. the information that conservationists have determined that the patch-burn method has promoted the growth of species that were at risk of being crowded out
 - D. the explanation that conservationists are able to control the fire in the patch-burn method by arranging separate burns across the designated portion of land

40. Which sentence supports the idea that farmers and people who manage land may be concerned about using fire as a way to benefit the land?

- E. "While one of the greatest threats to the prairie is wildfire, the use of controlled fires is actually an effective way to protect this idyllic landscape." (paragraph 1)
- F. "The American Indian people began to deliberately burn areas of land for bison to graze on, which enticed the herds away from the people's crops." (paragraph 2)
- G. "This patch burning contains the fire within a specific area and allows animals in the burn area to safely relocate." (paragraph 5)
- H. "The following year, conservationists will burn a different section of the preserve, while the land burned the previous year regrows healthier than before." (paragraph 5)

41. Read this sentence from paragraph 6.

Burning land to make it healthy may seem counterintuitive, but strategic controlled fires have helped the prairie sustain life for hundreds of years and, with careful management, will continue to do so.

The words "counterintuitive" and "strategic" in the sentence convey the idea that

- A. the safest methods are sometimes the least effective at solving complex challenges.
- B. thorough investigation of uncommon methodologies can lead to beneficial results.
- C. detailed planning can ensure that a potentially destructive action has a positive impact.
- D. plans that entail a certain amount of risk almost always result in success.

- 42.** With which statement would the author **most likely** agree?
- E.** It is important to explain the purposes and the risks of controlled burns to the people living near a proposed burn area.
 - F.** It is necessary to thoroughly examine a particular region in order to plan and execute a successful controlled burn.
 - G.** Monitoring animals' reactions after a controlled burn on the prairie is a minor part of scientists' research.
 - H.** Conservationists should consider the helpful aspects of invasive species before executing a controlled burn.
- 43.** How do the diagram and its text provide additional support for the topic presented in the passage?
- A.** by depicting how the landscape in a given area changes as the patch-burn method is applied
 - B.** by indicating that patch-burn fires are best suited for use in areas with certain features
 - C.** by revealing that the patch-burn method is used primarily on uninhabited areas of land
 - D.** by comparing the size of the area burned by the patch-burn method with that of unburned areas

CONTINUE TO THE NEXT PAGE ►

Ellen, the narrator, is preparing to leave her parents and the family farm for college the next day.

Excerpt from *Winter Wheat*

by Mildred Walker

- 1 I love Dad’s way of talking that makes him seem different from other ranchers. He’s lived here twenty-three years, but he still says “back East where I come from.” He’s the one who gets excited when I do about spring coming or a serial¹ running in the magazine we’re both reading, but it’s what Mom says that I depend on. When Mom used to say “Don’t worry” about my pet chicken or dog or new calf, it always got well. Dad is always talking of going some place, not now, but next year, maybe. Mom seems to think of nothing farther away than today or perhaps yesterday or tomorrow morning.
- 2 Mom folded the ironing board and put it inside their bedroom that was just off the kitchen. She carried in the freshly ironed clothes. Dad went back to his paper. When Mom came back she took beans from the cupboard to soak for tomorrow. Dad always said Mom could make all the dishes he’d had back in Vermont as well as though she were a New Englander herself, instead of a Russian. All of a sudden, I realized that tomorrow when those beans would be ready to eat I’d be going away. It gave me a funny feeling.
- 3 “I’ll be taking the train tomorrow night,” I said aloud, more to hear it myself.
- 4 “We can drive you into town in the afternoon,” Dad said, dropping his paper on the floor.
- 5 “There’s no need to go to town; she can catch the train at Gotham just as well. We haven’t nothing to take us into town for,” Mom said.
- 6 “Well, we don’t have to decide tonight,” Dad said, but I knew he wanted to go into Clark City. It wouldn’t be so flat as just seeing me go off on the train from Gotham. My going away was hard on both of them; they were so different—and I was part of them both. It made me uncomfortable to think of leaving them.
- 7 While I was getting ready for bed in my room that’s off the front room, I saw how it would be if I left from town. We’d go in right after dinner and go around to the stores, Dad going one way and Mom and I another. Dad would probably have his hair cut at the barbershop and stop in the bank and meet someone he knew to talk to. Then we’d meet at the big store on the corner and go to the cafeteria for supper. The train stops ten minutes or so at the station in town and there are other people and excitement and you have time to wave from the platform and then again from your window by your seat. We went to the station in Clark City to see the Goodals off when they went back to Iowa.
- 8 If I left from Gotham, we’d just drive down in the truck and wait till the train came. It only stops long enough for you to get on and you hardly have time to taste the flavor of going away.

¹**serial:** story published in short segments at regular intervals

- 9 I sat on the bed in my pyjamas with my arms around my knees. I couldn't keep from thinking of that time Dad went back East. I tried to, and then I just sat still and looked straight at it. Sometimes that's better than working so hard to keep from looking at what's in your mind.
- 10 Dad went all the way back to Vermont. . . . It was in November and it was already dark when the train came through Gotham. Even now, I could feel how cold and dark it was. I held Mom's hand. Dad was so dressed-up he seemed strange. . . . We stood there without saying anything until Dad told Mom to remember to call Mr. Bardich, our neighbor, if the cow didn't calve tomorrow.
- 11 "I'll manage," Mom snapped back.
- 12 "I wish you could go, Anna," Dad said to Mom, "and we could take Ellen." . . .
- 13 "Good-by, Anna Petrovna," he said, looking at Mom. I had never heard him call her by two names before.
- 14 "Good-by," Mom said, standing still, without smiling.
- 15 Then he was gone and the crossroads were darker than ever. The train light shone on the high window in the top of the grain elevator for a moment and then that too was dark. We got into our old Ford and Mom drove back to the house. My throat ached all the way. The name Dad had called Mom kept saying itself in my ears: "Anna Petrovna, Anna Petrovna." . . .
- 16 Our house seemed lonely when we came back to it. It seemed to be hiding under the coulee.² I went with Mom to put the truck in the barn that was bigger than the house. I think Mom was prouder of our barn than the house, anyway. We walked back to look at the cow that was going to calve. She was just a big light blob in the dark, waiting. I had thought she was exciting this morning, but now she seemed sad, too.
- 17 The wind blew when we walked across the open space to the house and I couldn't help shivering with the cold. Inside the house it was warm, but empty.
- 18 "Bring your nightgown in here and I heat you some milk," Mom said.
- 19 I drank the milk sitting on a stool in front of the stove. It tasted good, but the lonely ache in my throat was still there. I picked up my clothes and hung them neatly behind the stove and put my cup on the sink board. Mom was fixing oatmeal for tomorrow morning.
- 20 "Good night, Mom," I said almost timidly, standing beside her. She seemed wrapped around in a kind of strangeness. Then she turned around and drew me to her. The front of her dress was warm from the stove. I felt the comfortable heat through my gown. She laid her hand against my face and it felt rough and hard but firm. I dared ask her something I wanted to know.
- 21 "Mom, was that really your name—what Dad called you?"
- 22 Her voice sounded surprised. "Why, Yeléna, you know that; Anna Petrovna. You know I am born in Russia, in Seletskoe."

²**coulee:** small gulch or ravine

23 “Yes, but I didn’t know your other name,” I said.

24 “Anna Petrovna Webb.” She pronounced it slowly. “Once I think what a funny name Ben Webb is!” She laughed. Her laugh was warm and low like our kitchen, and comfortable. The house seemed natural and right again. . . .

25 But now that I am grown, I feel the wall of strangeness between them, more than when I was a child. I wondered how they would get along without me.

From WINTER WHEAT by Mildred Walker, published by University of Nebraska Press. Copyright © 1944 by Harcourt, Brace and Company, Inc. Copyright renewed 1971 by Mildred Walker. All rights reserved.

44. Read these sentences from paragraph 2.

Dad always said Mom could make all the dishes he’d had back in Vermont as well as though she were a New Englander herself, instead of a Russian. All of a sudden, I realized that tomorrow when those beans would be ready to eat I’d be going away. It gave me a funny feeling.

The sentences help develop a theme of the excerpt by

- E. suggesting that life presents people with many challenges.
- F. implying that the stress of major life events can cause confusion.
- G. demonstrating that moving on from the familiar is a common human experience.
- H. emphasizing the idea that people can easily learn the routines of being part of a new culture.

45. Read this sentence from paragraph 3.

“I’ll be taking the train tomorrow night,” I said aloud, more to hear it myself.

This remark contributes to the conflict in the excerpt by

- A. revealing Dad’s reasons for wanting to drive to the city.
- B. causing tension between Mom and Dad.
- C. leading Ellen to distance herself from both Mom and Dad.
- D. showing Mom’s reluctance to plan that far in advance.

46. Read this sentence from paragraph 9.

I tried to, and then I just sat still and looked straight at it.

How does the phrase “looked straight at it” contribute to the meaning of the excerpt?

- E. It shows that Ellen is willing to deal with a problem directly instead of ignoring it.
 - F. It suggests that Ellen studies all parts of an issue and not just its surface.
 - G. It illustrates that Ellen examines both sides of an argument.
 - H. It implies that Ellen is eager to seek wisdom from past experiences.
47. The words “cold” and “dark” affect the tone in paragraph 10 by
- A. highlighting the feeling of unpredictability among the family members.
 - B. showing the feelings of anger and resentment Ellen directs toward her parents.
 - C. exaggerating the feeling of regret Dad experiences when leaving his family.
 - D. emphasizing the feelings of separation and loss that Ellen feels.
48. Which sentence from the excerpt provides evidence that Ellen has a lot in common with her father?
- E. “He’s the one who gets excited when I do about spring coming or a serial running in the magazine we’re both reading. . . .” (paragraph 1)
 - F. “ ‘We can drive you into town in the afternoon,’ Dad said, dropping his paper on the floor.” (paragraph 4)
 - G. “ ‘Well, we don’t have to decide tonight,’ Dad said, but I knew he wanted to go into Clark City.” (paragraph 6)
 - H. “I wondered how they would get along without me.” (paragraph 25)

49. Read these sentences from the excerpt.

Mom seems to think of nothing farther away than today or perhaps yesterday or tomorrow morning. (paragraph 1)

Mom was fixing oatmeal for tomorrow morning. (paragraph 19)

The sentences help develop a central idea of the excerpt by

- A. suggesting that practical people focus on current needs rather than worrying about the future.
 - B. showing that parents tend to consider the needs of their children before thinking of themselves.
 - C. revealing that it is sometimes important to plan ahead.
 - D. illustrating that dreaming about the future is a waste of time.
50. The flashback in paragraphs 10–24 affects the plot by
- E. showing that the departure of one member of the family makes extra work for those left on the farm.
 - F. showing that the bond within the family persists even when its members are apart.
 - G. explaining why Ellen fears that leaving her parents will be too difficult.
 - H. illustrating the close connection Ellen has with both of her parents.
51. Which sentence from the excerpt provides evidence that Mom wants Ellen to understand the family’s heritage?
- A. “Mom folded the ironing board and put it inside their bedroom that was just off the kitchen.” (paragraph 2)
 - B. “ ‘There’s no need to go to town; she can catch the train at Gotham just as well.’ ” (paragraph 5)
 - C. “We’d go in right after dinner and go around to the stores, Dad going one way and Mom and I another.” (paragraph 7)
 - D. “ ‘Why, Yeléna, you know that; Anna Petrovna.’ ” (paragraph 22)

CONTINUE TO THE NEXT PAGE ►

Wolves of the Sea

- 1 The cool and misty landscape of the Great Bear Rainforest can be found along the coast of British Columbia, Canada, and its nearby islands, from Vancouver Island to the Alaskan border. Within this protected area, wolves roam the forests, islands, and beaches. When biologist Chris Darimont began to study these wolves, he wanted to confer with local First Nations groups, as aboriginal Canadians are known, in order to learn what they knew about these wolves. He spoke with Chester Starr, an elder of the Heiltsuk Nation that has occupied the Great Bear Rainforest for thousands of years. What Starr had to say about the wolves changed Darimont’s perception of the animals.
- 2 Starr asked Darimont which wolves he and his team were going to study—the timber wolves (mainland wolves) or the coastal wolves on the islands. The question took Darimont by surprise. Biologists had always believed that the wolves that are sometimes spotted swimming between islands and eating salmon are the same wolves that live on the mainland. Darimont was intrigued by Starr’s classification of the wolves as two different groups. At first, he was hesitant to accept the idea. The distances between the mainland and the islands are small, less than a mile. Why would the wolves on the islands be any different from the wolves on the mainland? To find out, Darimont and his research team studied the wolves on the islands and in the densely forested territory of the Great Bear Rainforest for ten years.
- 3 Throughout the study, Darimont recorded several significant, observable differences between the “sea wolves,” as they are nicknamed, and the mainland wolves. Compared with the mainland wolves, the sea wolves are smaller in size and are strong swimmers. In 1996 sea wolves were spotted on an island nearly eight miles from any other land formation. While mainland wolves almost exclusively eat meat, such as deer and elk, and teach their young to hunt for land animals, sea wolves get as much as 90 percent of their nutrition from the sea and teach their young to dig for clams and to catch fish. Sea wolves regularly swim between islands and have been known to sneak up on a seal sunning itself on a rock and make a leaping attack from the water. Some salmon-eating mainland wolves come and go from the islands with the fish-spawning season, but the sea wolves are full-time island residents. Darimont suspects that some sea wolves live their entire life on the islands.
- 4 The sea wolves displayed not only physical and behavioral differences but also genetic variations from the mainland wolves. After collecting and analyzing the DNA in 800 samples of gray fur and wolf waste, researchers could produce hard biological evidence that sea wolves had genetic markers that made them distinct from the mainland wolves. A genetic marker is a variation in a DNA sequence that can be used to identify individuals or a species because it is passed down to offspring. Darimont hypothesizes that a change in habitat led to the eventual genetic differences between sea wolves and mainland wolves. Many years ago, loss of habitat and food sources forced some mainland wolves out to the islands. They learned to eat everything from kelp and fish eggs to the remains of sea creatures that washed up on the beach. Wolves living on the islands and mainland wolves became more isolated and rarely mated with each other. Over time the two types of wolves became more distinct.
- 5 It turned out that Chester Starr was right all along. “It sounded totally bizarre at first,” admits Darimont, “that there could be two versions of the species.” But he now realizes that this skepticism “definitely reflected my ignorance of indigenous knowledge at the time.” Learning to

trust the wisdom of the Heiltsuk people opened Darimont up to knowledge accumulated over millennia and positioned him so that he could gather new scientific evidence about one of British Columbia’s most elusive species, the sea wolf.

- 52.** The details in paragraph 1 contribute to a central idea of the passage by showing that Darimont
- E.** believed the Great Bear Rainforest was an ideal location to study wolves in their natural habitat because it is a protected area.
 - F.** values different perspectives, because the information that Starr provided influenced the focus of Darimont’s research.
 - G.** thought the Great Bear Rainforest would provide opportunities to study different groups of wolves because the area includes forests and islands.
 - H.** understands the importance of respecting local community members, because Darimont sought permission from an elder of the Heiltsuk Nation before starting his research.
- 53.** Why does the author include details about the conversation between Starr and Darimont in paragraph 2?
- A.** to explain why Starr had closely observed the relationship between the two groups of wolves Darimont wanted to study
 - B.** to show that Darimont was hoping to work with Starr and to study both groups of wolves in the area
 - C.** to highlight that Darimont was unfamiliar with the area and expected Starr to help him find wolves to study
 - D.** to emphasize that the question asked by Starr caused Darimont to review his initial assumption about the wolves

54. Read this sentence from paragraph 4.

After collecting and analyzing the DNA in 800 samples of gray fur and wolf waste, researchers could produce hard biological evidence that sea wolves had genetic markers that made them distinct from the mainland wolves.

The phrase “hard biological evidence” conveys that the goal of the research team was to

- E. develop a procedure in order to ensure their study yielded plentiful data about the wolves.
- F. seek definitive scientific proof of the number of wolf species present in the area of the study.
- G. conduct a study to evaluate multiple theories about the diets of different wolf species.
- H. discover if the new data would provide information different from that of previous studies.

55. The author uses the word “admits” in paragraph 5 **most likely** to

- A. note that Darimont’s genetic research verified a theory based solely on field observations.
- B. imply that Darimont’s study was disappointing because the conclusion that he reached was not original.
- C. emphasize that Darimont’s study ultimately confirmed an idea that he had initially doubted.
- D. highlight that Darimont’s results led him to draw a conclusion from his research that his team did not agree with.

- 56.** Which sentence from the passage **best** supports the idea that sea wolves had successfully adapted to living on the islands?
- E.** “While mainland wolves almost exclusively eat meat, such as deer and elk, and teach their young to hunt for land animals, sea wolves get as much as 90 percent of their nutrition from the sea and teach their young to dig for clams and to catch fish.” (paragraph 3)
 - F.** “Sea wolves regularly swim between islands and have been known to sneak up on a seal sunning itself on a rock and make a leaping attack from the water.” (paragraph 3)
 - G.** “Darimont suspects that some sea wolves live their entire life on the islands.” (paragraph 3)
 - H.** “Darimont hypothesizes that a change in habitat led to the eventual genetic differences between sea wolves and mainland wolves.” (paragraph 4)
- 57.** How did a change in habitat **most** affect the wolf population of the Great Bear Rainforest over time?
- A.** It caused some of the wolves to learn new hunting techniques in order to catch increasingly scarce prey.
 - B.** It caused the wolves to form smaller packs and eventually separate, establishing distinct territories.
 - C.** It caused some of the wolves to gradually become a new, genetically distinct species as they adapted behaviorally.
 - D.** It caused the wolves to adapt their diet as different food sources became available in the area.

PART 2 — MATHEMATICS

57 QUESTIONS

IMPORTANT NOTES

- (1) Formulas and definitions of mathematical terms and symbols are **not** provided.
- (2) Diagrams other than graphs are **not** necessarily drawn to scale. Do not assume any relationship in a diagram unless it is specifically stated or can be determined from the information given.
- (3) Assume that a diagram is in one plane unless the question specifically states that it is not.
- (4) Graphs are drawn to scale. Unless stated otherwise, you can assume relationships according to appearance. For example, lines on a graph that appear to be parallel can be assumed to be parallel. This is also true for concurrent lines, straight lines, collinear points, right angles, etc.
- (5) Reduce (simplify) all fractions to lowest terms.

GRID-IN QUESTION NOTES

- (1) For each grid-in question, write your answer at the top of the grid.
- (2) Begin recording your answer in the columns on the far left.
- (3) Fill in the circle under the box that matches the number or symbol you wrote. Leave the negative sign bubble blank if your answer is positive.

(Answer: -1.5)

-	1	.	5	
<input checked="" type="radio"/>	<input type="radio"/>	<input type="radio"/>	<input type="radio"/>	<input type="radio"/>
0	0	0	0	
<input type="radio"/>	<input type="radio"/>	<input type="radio"/>	<input type="radio"/>	<input type="radio"/>
1	1	1	1	
2	2	2	2	
3	3	3	3	
4	4	4	4	
5	5	<input checked="" type="radio"/>	5	
6	6	6	6	
7	7	7	7	
8	8	8	8	
9	9	9	9	

Negative sign → ← Decimal point

(Answer: 3.2)

	3	.	2	
<input type="radio"/>	<input type="radio"/>	<input type="radio"/>	<input type="radio"/>	<input type="radio"/>
0	0	0	0	
<input type="radio"/>	<input type="radio"/>	<input type="radio"/>	<input type="radio"/>	<input type="radio"/>
1	1	1	1	
2	2	2	<input checked="" type="radio"/>	2
3	<input checked="" type="radio"/>	3	3	
4	4	4	4	
5	5	5	5	
6	6	6	6	
7	7	7	7	
8	8	8	8	
9	9	9	9	

Negative sign → ← Decimal point

CONTINUE TO THE NEXT PAGE ►

GRID-IN QUESTIONS

QUESTIONS 58–62

DIRECTIONS: Solve each problem. On the answer sheet, write your answer in the boxes at the top of the grid. Start on the left side of each grid. Print only one number or symbol in each box. Under each box, fill in the circle that matches the number or symbol you wrote above.

- Do not fill in a circle under an unused box.
 - Do not leave a box blank in the middle of an answer.
-

58. Ms. Li opened a retirement account with a deposit of \$2,500. This account earns 4% simple interest annually. How many years will it take her to earn \$500 on her \$2,500 deposit?

59. $6 - 9 \div |-3| + (-2)^3 \times 1\frac{1}{2}$

What is the value of the expression shown above?

60. Solve for x :

$$7x + 3 - 2(2x + 1) = 13$$

61.

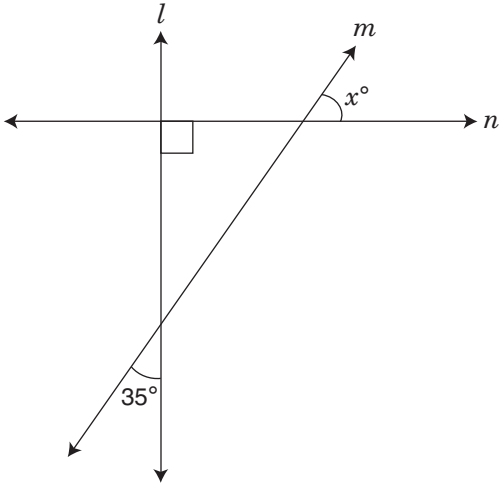

In the figure above, line l is perpendicular to line n . What is the value of x ?

62. The mean value of 8 numbers is 17. Three of these numbers (9, 11, and 20) are discarded. What is the mean of the 5 remaining numbers?

MULTIPLE CHOICE QUESTIONS

QUESTIONS 63–114

DIRECTIONS: Solve each problem. Select the answer from the choices given. Mark the letter of your answer on the answer sheet. When you are solving problems, you can write in the test booklet or on the scrap paper given to you.

63. $3^4 + 7^4 =$

- A. 40
- B. 370
- C. 2,482
- D. 10,000

64. In one week, $1\frac{3}{4}$ inches of rain fell on Monday, $2\frac{2}{3}$ inches fell on Tuesday, and $\frac{7}{8}$ inch fell on Wednesday. How many inches of rain fell during those three days?

- E. $5\frac{7}{24}$
- F. $5\frac{1}{24}$
- G. $3\frac{4}{5}$
- H. $3\frac{1}{2}$

65. Jamel works at a computer store. He is paid an hourly rate plus a 15% commission on all computer products he sells. Last week, Jamel was paid \$802.50 for working 30 hours and selling \$1,250.00 worth of computer products. What is Jamel's hourly rate?

- A. \$20.50/hr
- B. \$26.75/hr
- C. \$33.00/hr
- D. \$37.65/hr

66. A revolving sign makes 1 complete revolution every 90 minutes. If the sign starts moving at 2:30 p.m., at what time will the sign complete 8 revolutions?

- E. 1:00 a.m.
- F. 2:30 a.m.
- G. 4:00 p.m.
- H. 12:00 midnight

67.

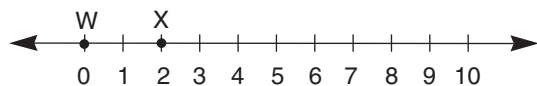

Points Y and Z are not shown on the number line above. If X is the midpoint of \overline{WY} , and Y is the midpoint of \overline{WZ} , where on the number line would point Z be located?

- A. 2
- B. 4
- C. 6
- D. 8

68.

$$\frac{81}{10} = \frac{9}{n}$$

What value of n makes the equation above true?

- E. 1
- F. $1\frac{1}{9}$
- G. 5
- H. $10\frac{1}{9}$

69. If n is an integer and $3n + 3$ is an even number, which expression must also represent an even number?

- A. $5n + 1$
- B. $4n + 5$
- C. $2n + 3$
- D. $n + 2$

70. The product of two positive integers is 65. Which number could be the sum of the two integers?

- E. 5
- F. 18
- G. 24
- H. 52

71. If n is an odd integer that is less than -3.25 , what is the **greatest** possible value of n ?

- A. -1
- B. -2
- C. -3
- D. -5

72. A swim instructor used the box plot below to display the distribution of the ages of students who signed up for swim lessons.

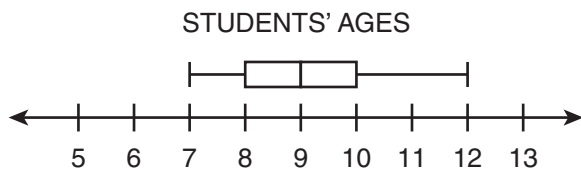

Which statement about the distribution of ages is true?

- E. The data contain an outlier.
- F. Approximately half the students are exactly 9 years old.
- G. Approximately one-fourth of the students are at least 10 years old.
- H. The interquartile range is 3 greater than the range of the data.

73. Between which two consecutive integers is the fraction $\frac{29}{7}$?

- A. 2 and 3
- B. 3 and 4
- C. 4 and 5
- D. 5 and 6

74. A customer wants to buy a pair of hiking boots.

- The original price of the boots is \$85.75.
- The store is offering a 15% discount on all boot purchases.
- The customer has a coupon for an additional 25% off the sale price.
- The tax rate is 8.5%.

What is the final cost of the boots, including the tax, to the nearest cent?

- E. \$55.82
- F. \$59.08
- G. \$59.32
- H. \$63.17

75. Sheila is saving money for her summer vacation. She starts the summer with a balance of \$90.00 and plans to save 15% of her earnings each week. She earns the same amount each week. After 12 weeks, Sheila has saved a total of \$472.59. How much money does Sheila earn each week?

- A.** \$212.55
- B.** \$262.55
- C.** \$302.55
- D.** \$312.55

76. $x:35 = 20:28$

For what value of x is the proportion shown above true?

- E.** 27
- F.** 25
- G.** 16
- H.** 13

77.
$$\frac{3^2 + (-8)^2 + 2^2}{(3 - 8 + 2)^2} =$$

- A.** -60
- B.** $-\frac{17}{3}$
- C.** $\frac{77}{9}$
- D.** 68

78. A soccer coach purchased 15 pairs of cleats for team members and spent a total of \$805.95, including tax. If the tax rate is 8%, what is the price of each pair of cleats before tax?

- E.** \$49.43
- F.** \$49.75
- G.** \$53.73
- H.** \$58.03

79. The numbers m , n , p , and q are different, and each is equal to one of the numbers 1, 2, 3, 6, or 12. If $2m = 6q = \frac{1}{2}n = p$, what is the value of p ?
- A. 2
 B. 3
 C. 6
 D. 12

80. $\{0.1, 0.01, 0.001, 0.0001, 0.00001\}$

If a person chooses a number at random from the set above, what is the probability that the number is less than 0.005?

- E. $\frac{1}{5}$
 F. $\frac{2}{5}$
 G. $\frac{3}{5}$
 H. $\frac{2}{3}$

81. A student uses Spinner R and Spinner T to generate a list of two-digit numbers.

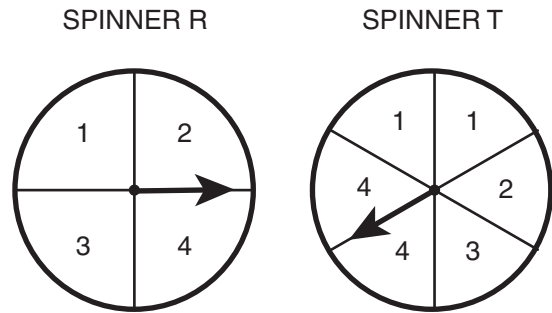

Spinner R determines the digit in the tens place, and Spinner T determines the digit in the ones place. What is the probability that the two-digit number determined by spinning each spinner one time is a prime number?

- A. $\frac{3}{8}$
 B. $\frac{5}{12}$
 C. $\frac{3}{5}$
 D. $\frac{5}{8}$

82.

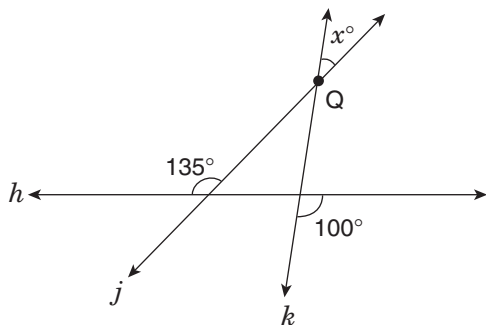

Lines j and k intersect at point Q , and h is a straight line. What is the value of x ?

- E. 55
- F. 45
- G. 35
- H. 30

83. Which statement **must** be true if x is a whole number greater than or equal to 1?

- A. $\frac{1}{x+1} > \frac{1}{x+2}$
- B. $\frac{1}{x+1} < \frac{1}{x+2}$
- C. $\frac{1}{x+1} - \frac{1}{x+2} > 1$
- D. $\frac{1}{x+1} - \frac{1}{x+2} > \frac{1}{x}$

84. A basket contains red balls, green balls, and white balls. There are 12 red balls in the basket. The probability of randomly choosing a red ball is 1 in 3. If the probability of randomly choosing a green ball is 1 in 4, how many green balls are in the basket?

- E. 3
- F. 8
- G. 9
- H. 16

85. It took Lars 2 hours to ride his bicycle 48 kilometers. What was his average speed in **miles per hour**? (Use the approximation 1 mile = 1.6 kilometers.)

- A. 1.5
- B. 15.0
- C. 30.0
- D. 38.4

86. Integer x is evenly divisible by 3. Which expression below is also evenly divisible by 3?

- E. $2x + 1$
- F. $3x - 5$
- G. $4x - 1$
- H. $4x + 6$

87. Lamel has a jar containing 6 red chips, 10 blue chips, and 4 yellow chips. If he removes one chip at random, what is the probability that it will **not** be red?

- A. $\frac{4}{5}$
- B. $\frac{7}{10}$
- C. $\frac{3}{10}$
- D. $\frac{1}{5}$

88.

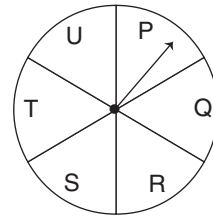

The arrow starts on Space P and moves clockwise around the circle. It moves through one space each minute. What space will the arrow point to in 100 minutes?

- E. R
- F. S
- G. T
- H. U

89. Mei-Ling is one of 6 members of a committee. If 2 members of that committee are selected to go to a conference, how many of the possible pairs of members would include Mei-Ling?

- A. 5
- B. 6
- C. 10
- D. 12

90. If $m = 5$ and $t = -1$, what is the value

of $\frac{6 - 8(2 - t)}{2m + 4(3 - m)}$?

- E. -9
- F. -1
- G. 1
- H. 9

91.

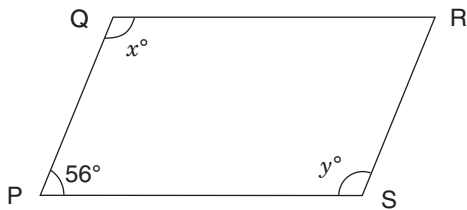

In the parallelogram above, what is the value of $x + y$?

- A. 112
- B. 124
- C. 148
- D. 248

92.

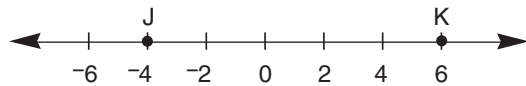

On the number line above, point L (not shown) is located on line segment JK so that $JL = \frac{2}{3}LK$. What is the position of point L?

- E. -2
- F. 0
- G. 2
- H. 4

93. Josef and Mai divided some stamps between themselves. Josef got 60% of the stamps. If Josef received 500 more stamps than Mai, how many stamps did Josef receive?

- A. 300
- B. 800
- C. 1,500
- D. 2,500

94.

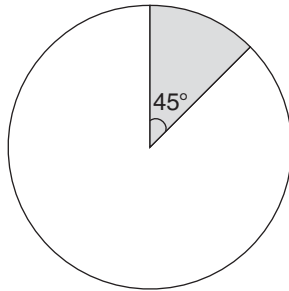

The shaded sector of the circle shown above has an area of 18π square feet. What is the **circumference** of the circle?

- E. 144π ft
- F. 24π ft
- G. 18π ft
- H. 9π ft

95. Which graph represents the solution to $-3x - 7 > -4$?

- A. A number line from -4 to 4 with tick marks at every integer. A solid circle is at -1, and a ray extends to the left from -1.
- B. A number line from -4 to 4 with tick marks at every integer. A solid circle is at 1, and a ray extends to the left from 1.
- C. A number line from -4 to 4 with tick marks at every integer. A solid circle is at -1, and a ray extends to the right from -1.
- D. A number line from -4 to 4 with tick marks at every integer. A solid circle is at 1, and a ray extends to the right from 1.

96. A scientist mixed three chemicals, R, S, and T, in a glass container. The amount of R is 3 times the amount of S, and the amount of T is $\frac{1}{6}$ the amount of S. What is the ratio of the amount of R to the amount of T?

- E. 1:18
- F. 2:1
- G. 3:1
- H. 18:1

97. Ken has k video games, and Jeff has j video games. If Ken gives 6 video games to Jeff, Ken will have twice as many video games as Jeff. Which equation shows the relationship between k and j ?

- A. $k - 6 = 2(j + 6)$
- B. $k - 6 = 2j + 6$
- C. $2(k - 6) = j$
- D. $2(k - 6) = j + 6$

98. Yesterday Sarah read 15% of her entire book. Today she read another 17% of the entire book. In lowest terms, what fraction of the book is left for her to read?

E. $\frac{7}{25}$

F. $\frac{3}{10}$

G. $\frac{17}{25}$

H. $\frac{7}{10}$

99. $\{1,2,3,4,5,\dots,198,199,200\}$

How many members of the set shown above are multiples of 6 but **not** multiples of 9?

A. 11

B. 13

C. 20

D. 22

100. Kim jogs 8 kilometers in 1 hour 40 minutes. At that rate, how many **meters** does she jog per minute?

E. 0.08

F. 80

G. 800

H. 8,000

101. For what value of x is the equation

$$\frac{x}{5} - 4 = 3(4 - 2x) - 1$$
 true?

A. $\frac{75}{11}$

B. $\frac{75}{31}$

C. $\frac{15}{7}$

D. $\frac{65}{31}$

102.

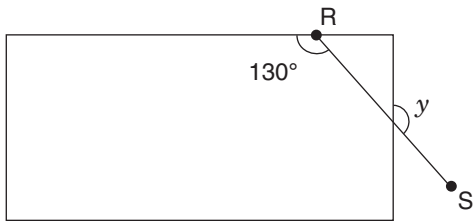

The diagram above shows line segment RS intersecting a rectangle. What is the measure of angle y ?

- E. 140°
- F. 130°
- G. 50°
- H. 40°

103.

ESSAY LENGTH

Number of Words	Number of Essays
<100	6
100–250	4
251–500	11
>500	9

All 150 students in Grade 8 at a school are assigned to write an essay on the same topic. A teacher records the number of words in a random sample of the essays, as shown in the table above. Based on this sample, how many students in the entire grade would be expected to write essays with **at least** 100 words?

- A. 20
- B. 30
- C. 100
- D. 120

104. Which percentage is closest in value to 0.0099?

- E. 0%
- F. 0.1%
- G. 1%
- H. 100%

105. The manager of a shipping company recorded the weights, in pounds, of the last 9 packages the company shipped. The manager displayed the distribution of the weights in a box plot with the five-number summary shown below:

- minimum: 29
- first quartile: 31
- median: 42
- third quartile: 73
- maximum: 98

Which statement about the distribution of weights is supported by the box plot the manager created?

- A.** The minimum, 29, is an outlier.
- B.** The maximum, 98, is an outlier.
- C.** The interquartile range of the data is 11.
- D.** The interquartile range and the median are equal.

106.

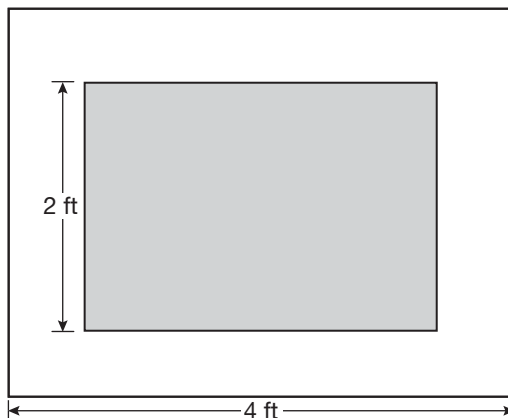

In the figure above, the shaded rectangle is similar to the outer rectangle. The length of the outer rectangle is 4 feet, and the perimeter of the outer rectangle is 14 feet. If the width of the shaded rectangle is 2 feet, what is the area of the shaded rectangle?

- E.** $5\frac{1}{3}$ sq ft
- F.** 6 sq ft
- G.** $9\frac{1}{3}$ sq ft
- H.** 12 sq ft

107. A rectangular concrete driveway is 30 feet long, 8 feet wide, and 6 inches thick. What is the volume of the concrete?

- A.** 44 cu ft
- B.** 48 cu ft
- C.** 120 cu ft
- D.** 240 cu ft

108. At a carnival, visitors can win a prize if an employee cannot correctly guess their age. The employee records the first 15 ages that he guesses one Saturday. The box plot shown below displays data about the ages he recorded.

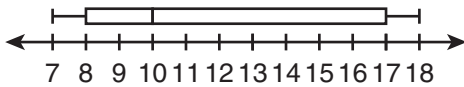

What is the interquartile range of the box plot?

- E.** 7
- F.** 9
- G.** 10
- H.** 11

109. Vicente and Carla each ran 8 laps around a track. They started at the same time and place. If Vicente ran 1.5 times as fast as Carla, how many laps did Carla have left to finish when Vicente finished his 8th lap?

- A.** $2\frac{1}{2}$
- B.** $2\frac{2}{3}$
- C.** $3\frac{1}{3}$
- D.** $5\frac{1}{3}$

110. At West College, students are randomly assigned to one of 20 dormitories and one of 6 dining rooms. Kharleen likes 6 of the dormitories and 2 of the dining rooms. What is the probability that she is assigned to both a dormitory and a dining room that she likes?

- E.** 10%
- F.** 12%
- G.** 19%
- H.** 38%

111. A train travels 2,200 miles from Phoenix to New York City. The train covers the first 240 miles in 5 hours. If the train continues to travel at this rate, how many **more** hours will it take to reach New York City? Round your answer to the nearest whole hour.

- A.** 46
- B.** 45
- C.** 43
- D.** 41

112. What is the **least** of four consecutive integers whose sum is 58?

- E.** 1
- F.** 2
- G.** 12
- H.** 13

113.



If all possible values of x are indicated by the shaded part of the number line above, which number line best shows all possible values of $\frac{1}{x}$?

- A.
B.
C.
D.

114. Chanelle selects a marble from a container and then returns it to the container. When she does this 3 times, the probability of choosing a red marble all 3 times is $\frac{1}{216}$. Based on this information, what is the probability of Chanelle choosing a red marble the **first** time she selects a marble?

- E. $\frac{1}{72}$
F. $\frac{1}{36}$
G. $\frac{1}{8}$
H. $\frac{1}{6}$

THIS IS THE END OF THE TEST.
IF TIME REMAINS, YOU SHOULD CHECK
YOUR ANSWERS. BE SURE THAT THERE
ARE NO STRAY MARKS, PARTIALLY
FILLED ANSWER CIRCLES, OR
INCOMPLETE ERASURES ON YOUR
ANSWER SHEET. ■